



2023

浦林成山企业简介



CONTENT



关于我们



竞争优势



发展战略



社会责任

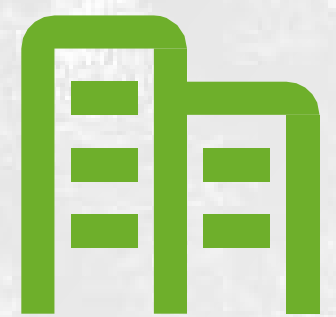

关于我们



企业简介

浦林成山控股有限公司业务源于1976年，致力于绿色、安全、高品质、高性能乘用车轮胎、卡客车轮胎、工程胎及空气弹簧的研发、生产与销售。

PRINX CHENGSHAN



2018年10月9日
浦林成山于香港联交所主板上市
股票代码1809.HK

绿色

安全

高品质

高性能

经营理念



企业理念

专注于轮胎行业
以创新驱动绿色、高效、可持续发展



愿景使命

引领轮胎创新
贡献智慧出行和可持续发展，成就美好生活



核心价值观

客户至上、尽责担当、专注专业、创新开放

47年发展里程碑

1976 — 2004

初始建厂

- 1976 荣成市橡胶厂成立
- 1990 建立国内首条自主研发子午线轮胎生产线
- 2003 荣成橡胶厂改制为成山集团

2004

2005 — 2015

战略布局

- 2005 与美国Cooper合资
- 2015 中国重汽成为战略合作伙伴

2015

2016 — 2017

加速发展

- 2016 浦林（欧洲）注册成立
- 2017 浦林（青岛）成立 扩强研发

2017

2018 — 2020

香港上市 海外建厂

- 2018 于香港联合交易所主板上市 股票代码1809.HK
- 2019 美国分公司成立
- 2020 泰国生产基地投产

2020

2021 — 未来

向未来...

- 2021 浦林成山（上海）投资有限公司挂牌成立
- 2022 四大品牌全面焕新 新浦林全面发力新能源市场
- 2023 成山品牌“华”系列 -华悦SUV新品上市 欧洲浦林全系列新品上市
- 未来

企业规模



卡客车轮胎 | 产能**940万条**

乘用车轮胎 | 产能**1920万条**

斜交胎 | 产能**120万条**

工程胎 | 产能**5万条**

空气弹簧 | 产能**50万套**

*数据截至时间：2022年年中报
*22年年收入：待公布年报后更新



第一

智安达-行业第一服务方案

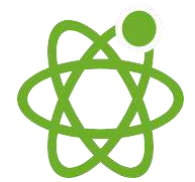

唯一

山东省制造业创新中心



第一

全国轮胎行业第一批申请
能源管理体系认证企业

行业地位
NO.1

第一

中国第一条
自主研发国产子午线轮
胎生产线



第一

国家第一批绿色工厂



第一

国家级企业技术中心
连续四届八年中国轮
胎行业排名第一







率先提出多尺度轮胎全
生命周期的概念







参与制定及修订20项
国家相关行业标准







90年代在国内率先创
立创新研发中心



重要荣誉



中国轮胎10大影响力品牌

国家科技进步二等奖

能效领跑者标杆企业

年度十大创新发展奖

中国500最具价值品牌

2021山东省长质量奖

首届金蜂奖 公益先锋奖

国家高新技术企业

最佳工业制造公司

卡车兄弟信赖产品

中国石油化工行业500强

2021行业品质典范奖

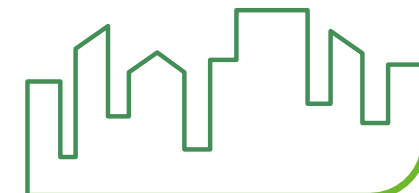
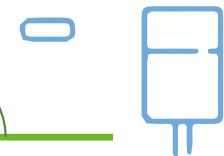
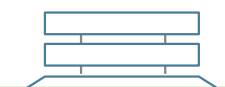
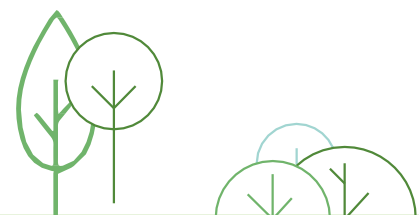

*奖项截至时间：2023年1月



竞争优势



业务规模

1  家新业务公司

2  个研发中心

2  个生产基地

6  个销售公司

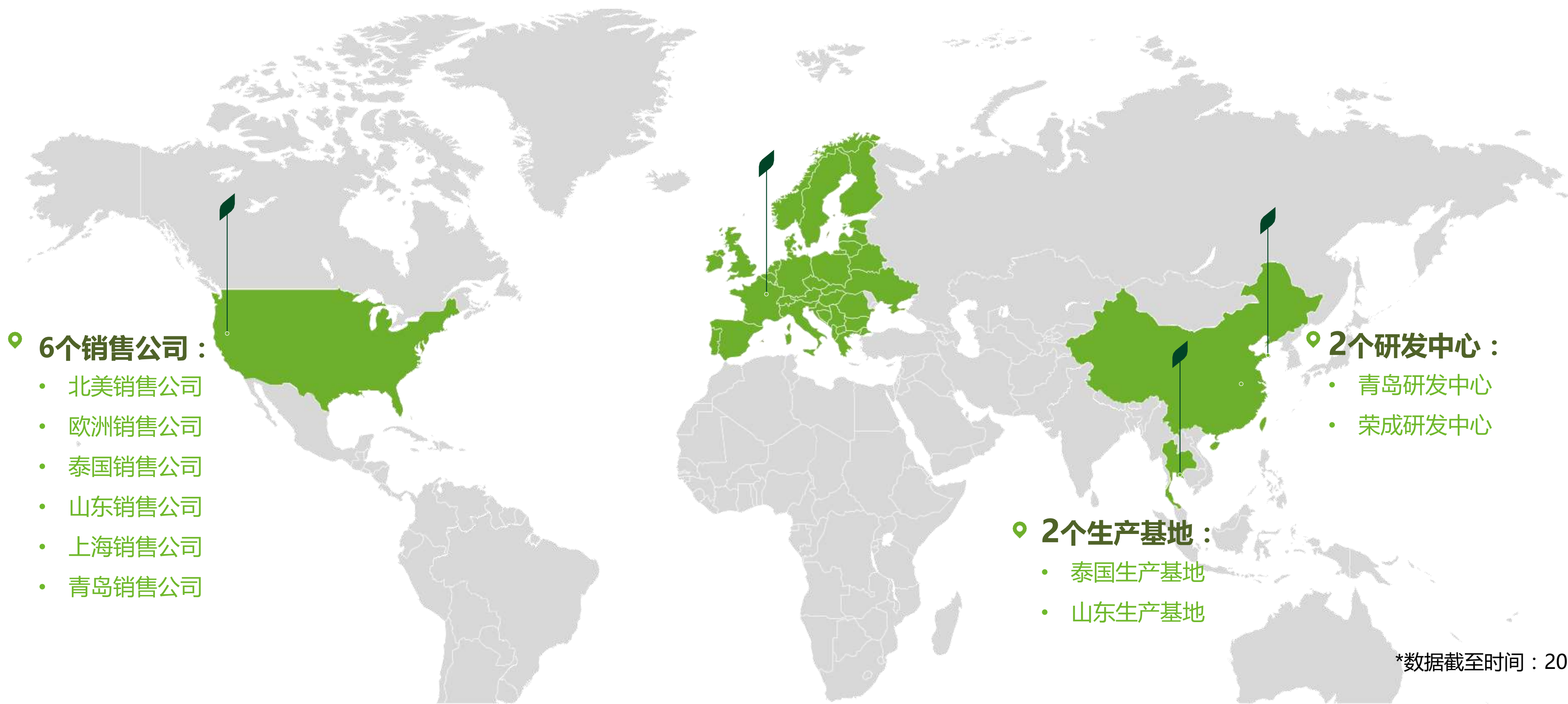

研发实力

两大研发中心

青岛研发中心
QINGDAO

荣成研发中心
RONGCHENG

三大轮胎设计与仿真系统



数字化轮胎设计系统DTDS



轮胎趾纹性能预报平台TP3



轮胎仿真系统TSS

研发实力

配方改良与创新



自主创新

提前布局新能源电动汽车轮胎领域，深入研究新能源汽车轮胎特性，在橡胶配方中引入先进弹性体材料提升轮胎性能，保证轮胎在全路况下的卓越性能。



研发合作

与国内外知名校企进行产学研合作，吸收国外绿色节能环保轮胎开发技术，与国外先进轮胎生产技术同步更新。



专利成果

321 项知识产权专利

包括 16 项发明专利

研发实力

新能源电动汽车轮胎技术

- 先进弹性体与高分散填料结合更紧密，更耐磨、长续航、抗湿滑。

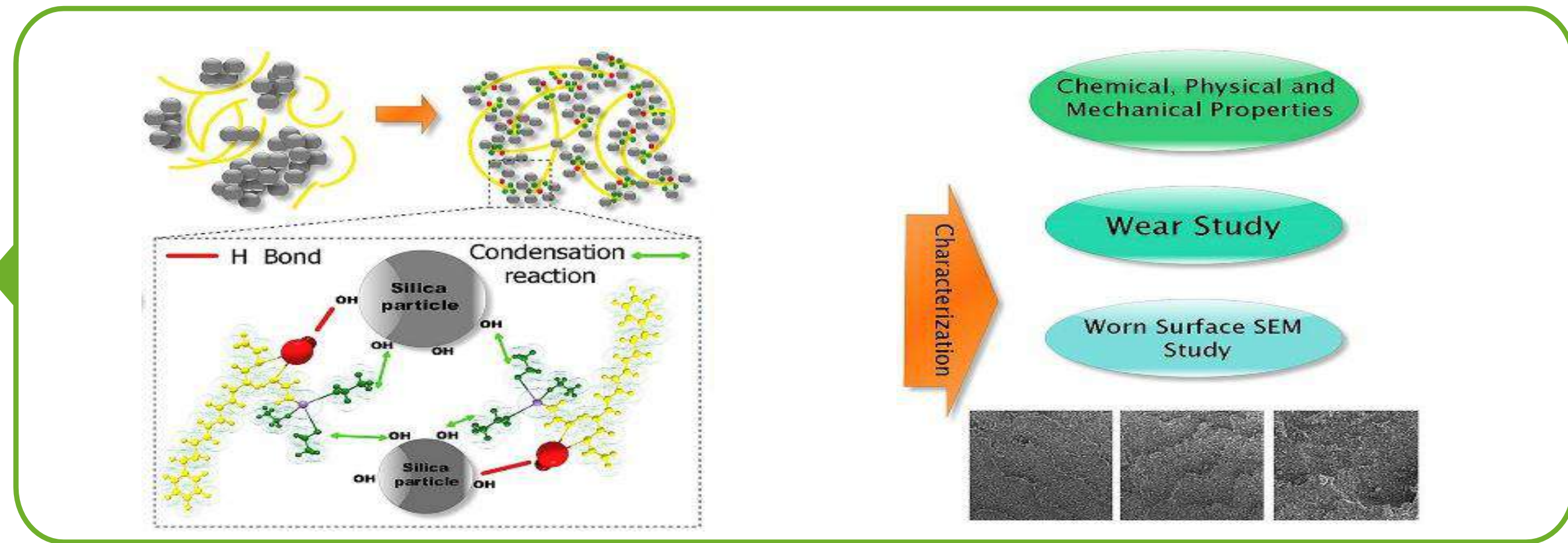

静音棉技术
静享舒适



自修复技术
安全无忧



全胎侧天鹅绒
实力与颜值担当



彩色可定制轮胎
满足消费者个性化需求

研发实力 有限元分析能力

静态接地印痕仿真

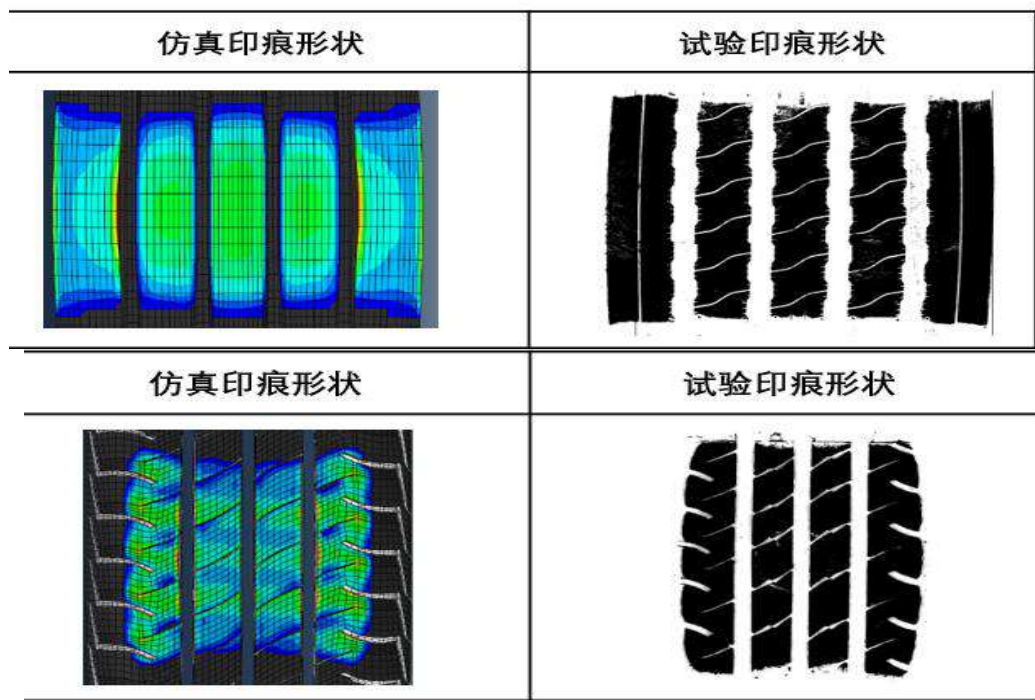

六分力仿真

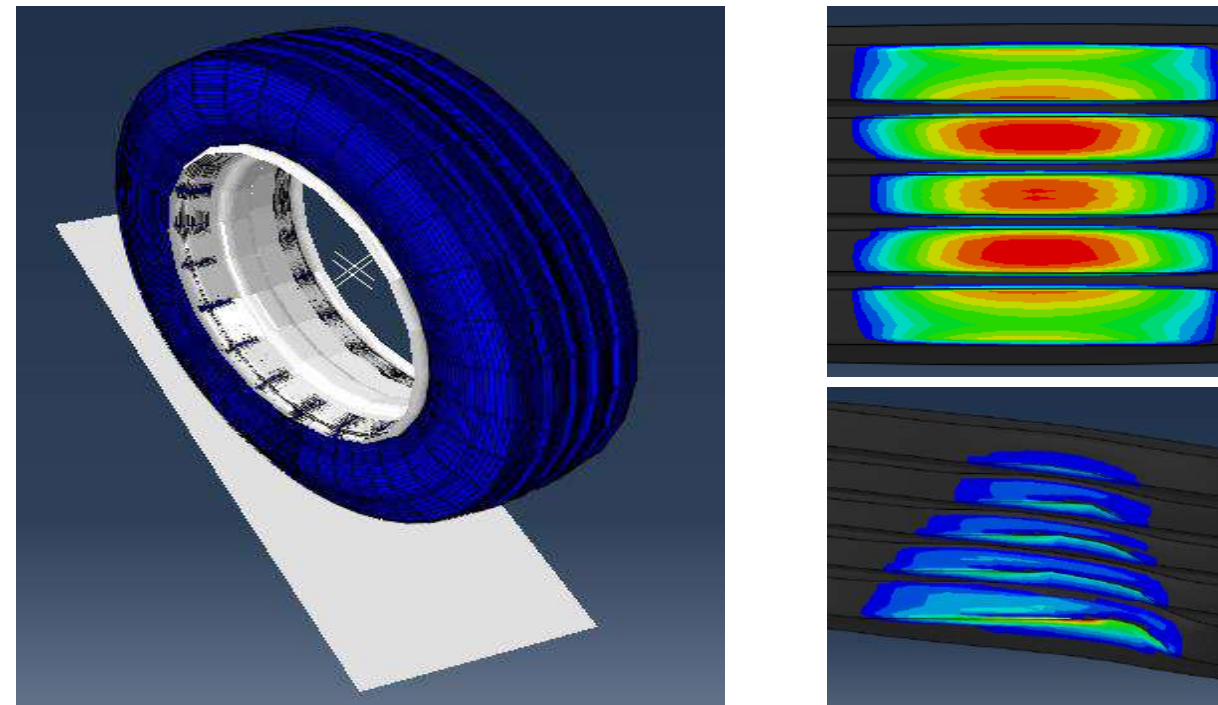

滚阻温度场仿真

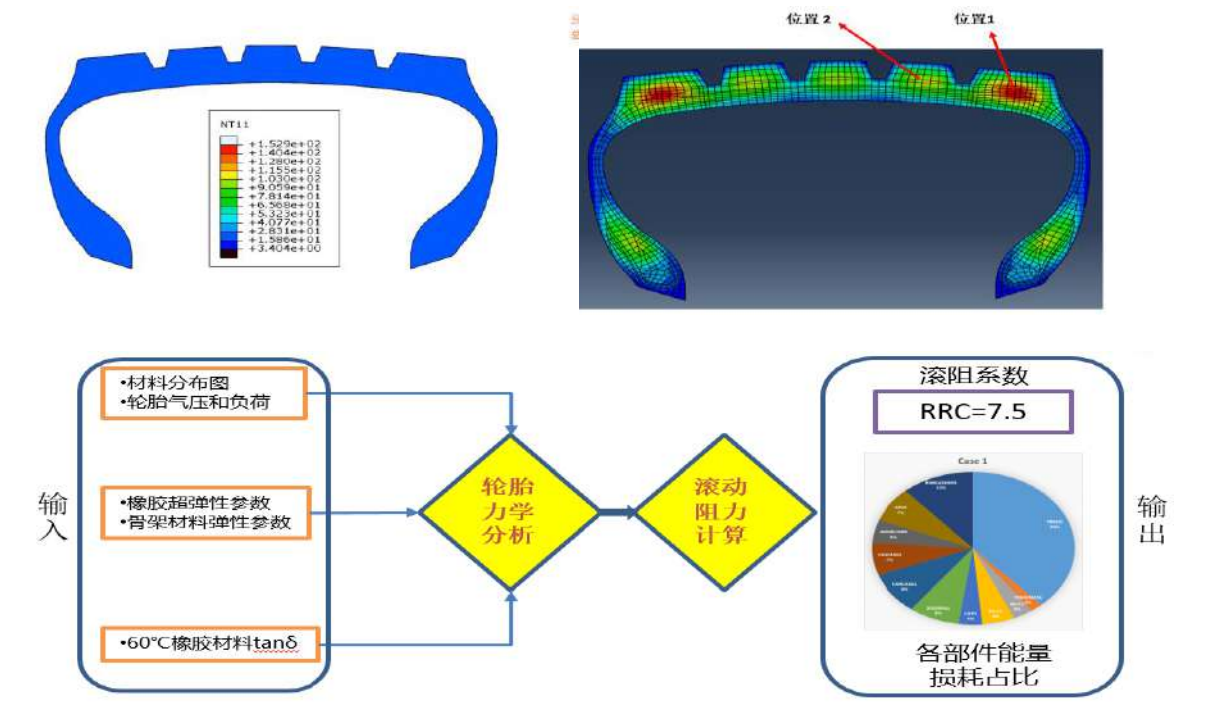

脱圈试验仿真

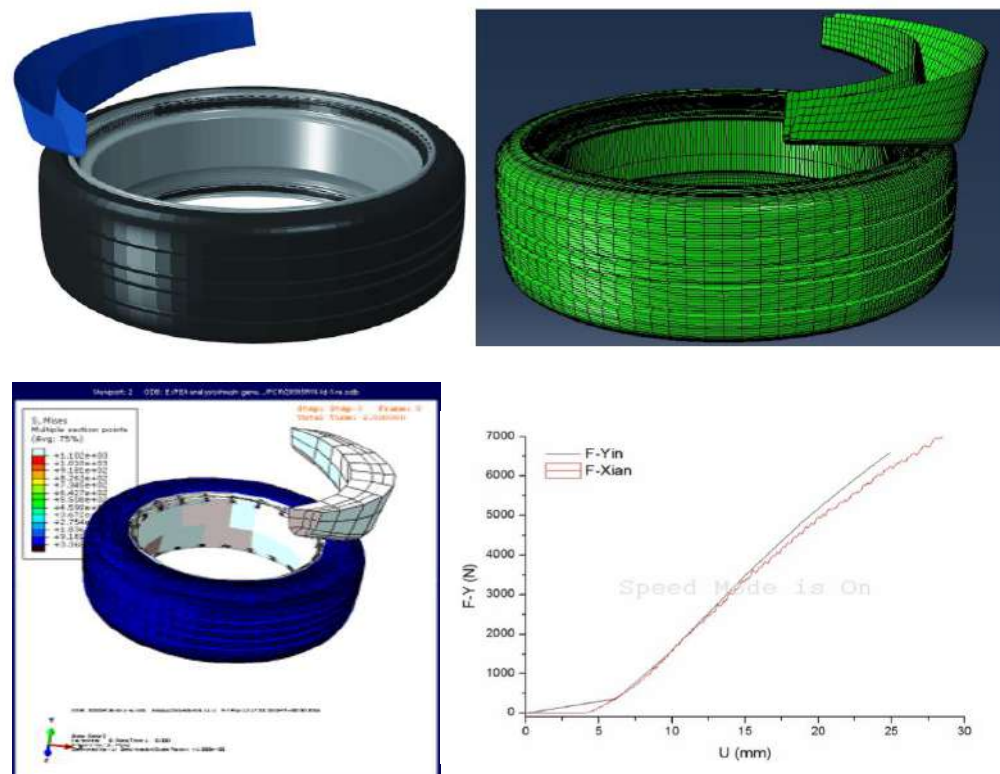

磨耗仿真

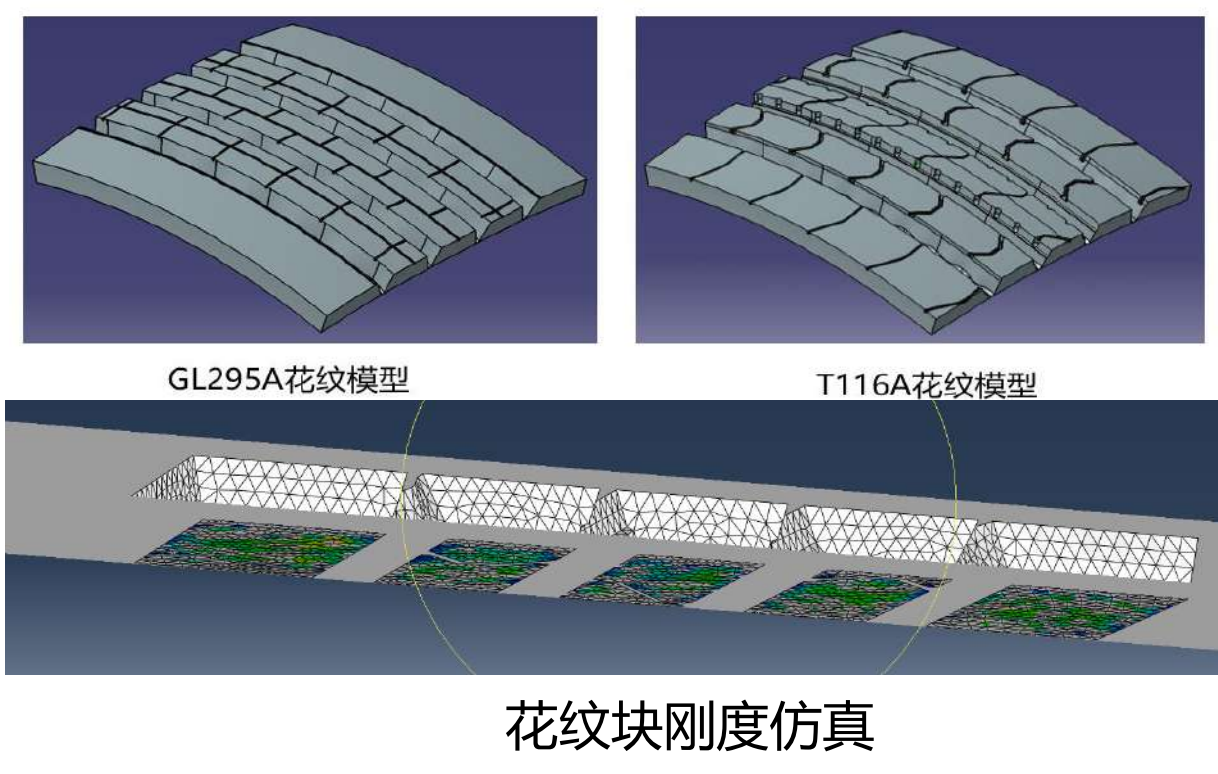

模态仿真

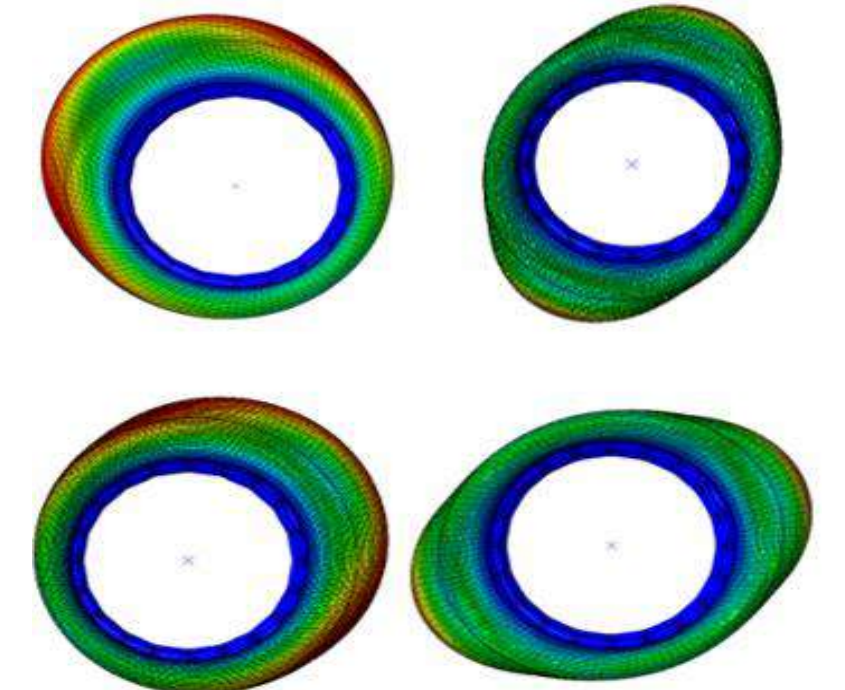

配套实力



与中国重汽、江铃汽车、上汽依维柯红岩等**68**家主机厂进行配套合作

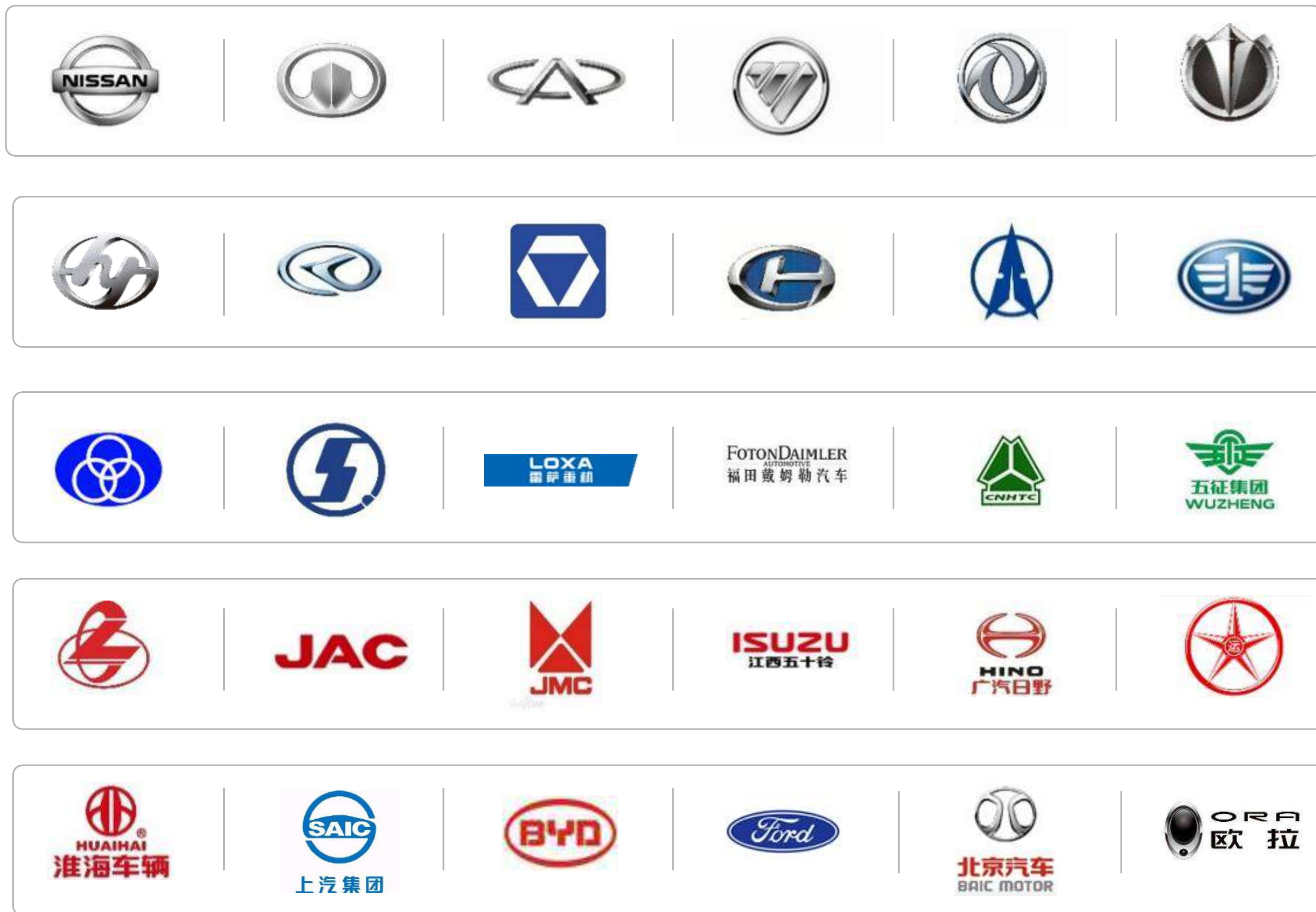

*数据截至时间：2023年1月

产品与服务全生命周期的质量管理



质量和产品认证

公司先后通过IATF16949质量体系认证、ISO14001环境体系认证、OHSAS18001职业健康安全管理体系认证、ISO17025实验室认可、测量管理体系认证、知识产权管理体系、AAAA标准化体系等。

质量体系认证



产品认证



国际认证



China
CCC



U.S
DOT



EU
ECE



EUR117



Brazil
INMETRO



Gulf
Area
GSO



Saudi
SASO



Nigeria
SONCAP



Uruguay
LATU



Thailand
TISI

专家顾问式指导服务客户

市场服务人员全部通过“国家橡胶轮胎质量监督检验中心”的培训且获得《汽车轮胎理赔员资格证》。



解决方案提供

拥有20年丰富经验的专家直接进入终端市场，为客户提供最佳的轮胎故障识别解决方案。

4年保修期

每一条轮胎保修期均为自生产之日起4年（高于行业平均）。



发展战略



国际化 | 国际经销网络遍布全球

遍布全球 **6** 大洲

一级经销商近
600家

为全球 **2000+**
星级门店的赋能

产品覆盖全国和国外
169个国家和地区

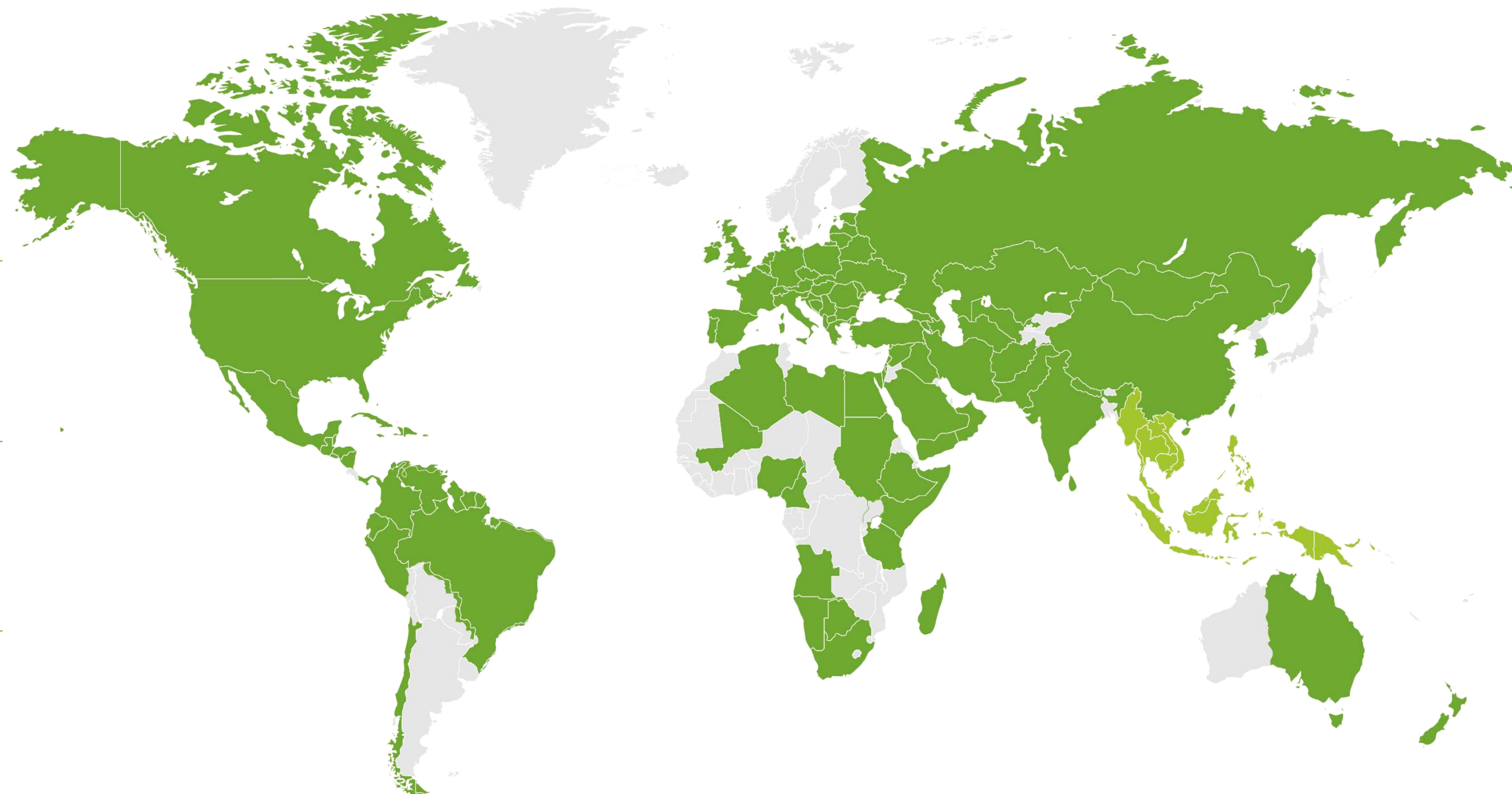

国际化 | 国际优质供应链体系



智能化 | 智能工厂与智慧管理



数据智能

各业务领域数据采集与有效分析，实现从状态感知-实时分析-科学决策-精准执行的闭环管理。



企业运营

实现物料采购到生产投入，产品销售到到货陈列各项企业资源的全面信息覆盖，建立开放式物联网平台。



制造管理

实现数字化产品设计、结构化工艺规划，制造过程排产、调度、库存、质量、物料、设备、能源、人员全流程数字化，支持连续性个性化制造。



现场控制

采用领先的技术装备，实现生产、物流过程的自动化。

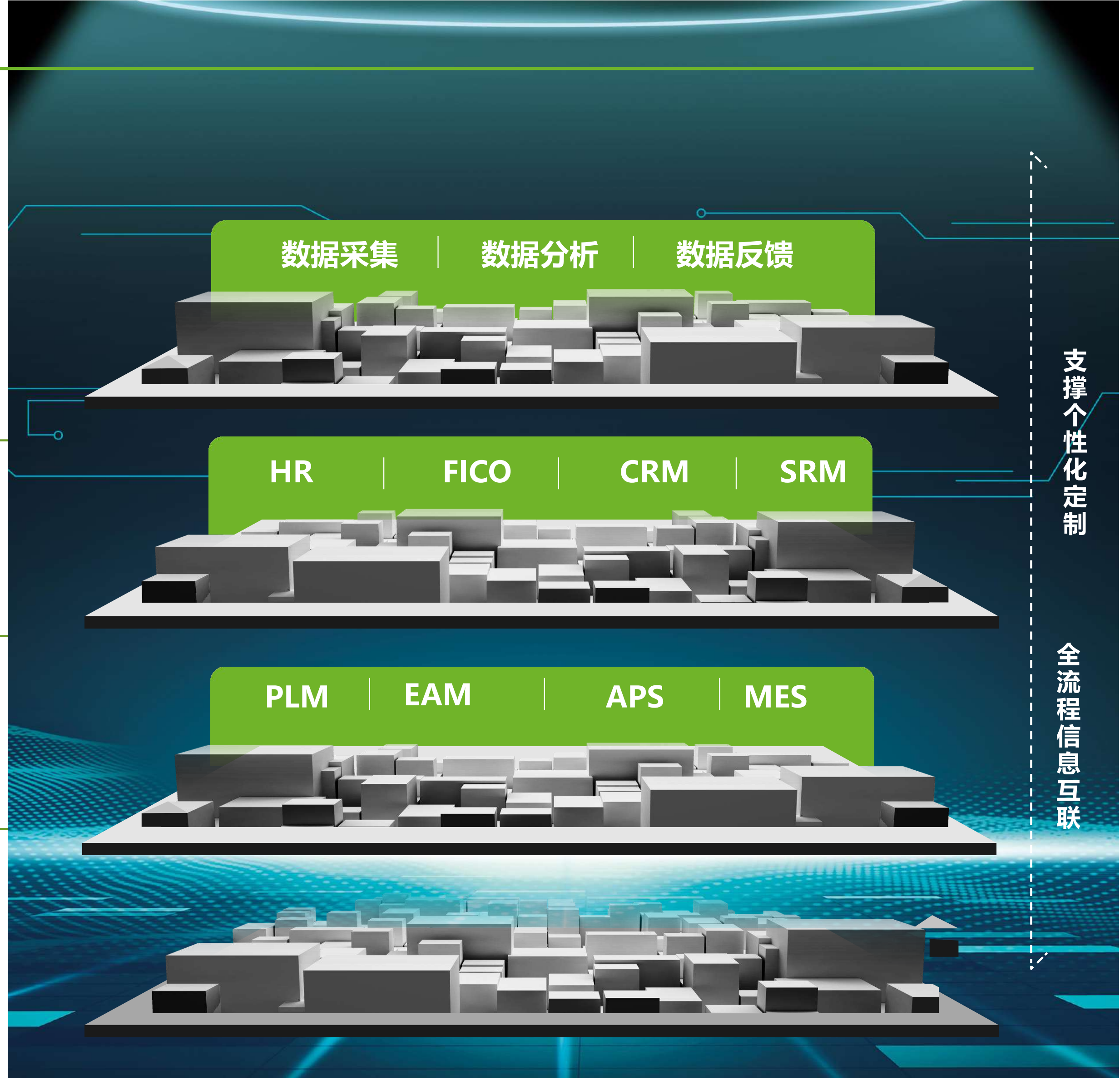

智能化

行业第一服务解决方案

200+家

200+家物流公司
或集团客户选择
智安达服务

7000+

智能轮胎技术应用于
7000+辆车

14万+

14万多个轮位



10万+

每年服务10万+条
轮胎采用全生命
周期数据

**110万
公里**

智安达数据管理服务车
辆每天行驶110万公里

TOP.5

中国快递运输业五
强三家选择智安达

未来，智安达将围绕“为用户创造更高价值”
在更多领域创造更多服务价值

*数据来源：智安达数据

智能化

数字化渠道多元布局

乘用车：小浦云店 商用车：灯塔e站

转型升级，助力门店创富

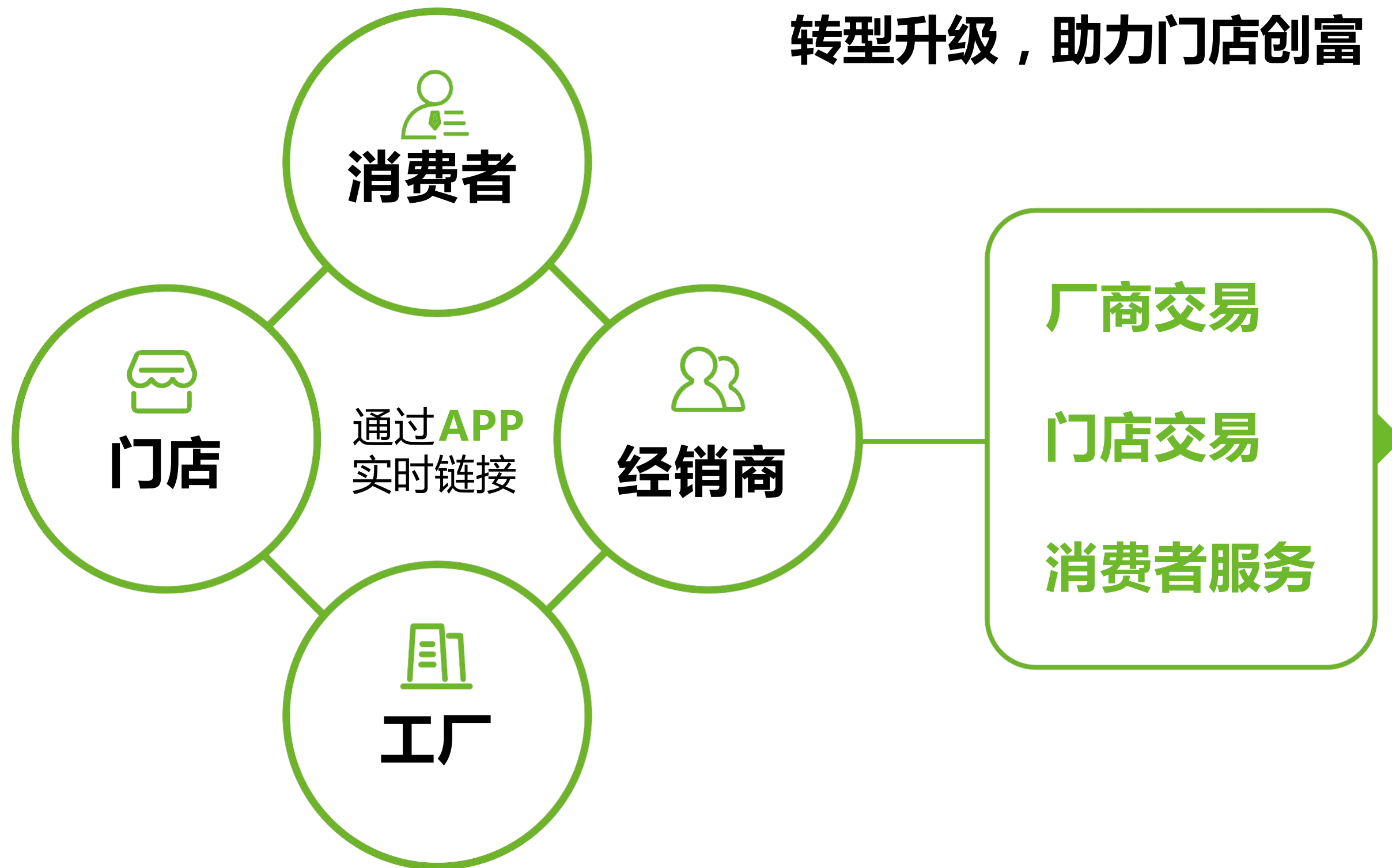

小浦云店

18000+

门店注册



灯塔e站

2000+

门店注册

品牌化 | 多品牌差异化发展

PRINX 浦林
为电动时代而生

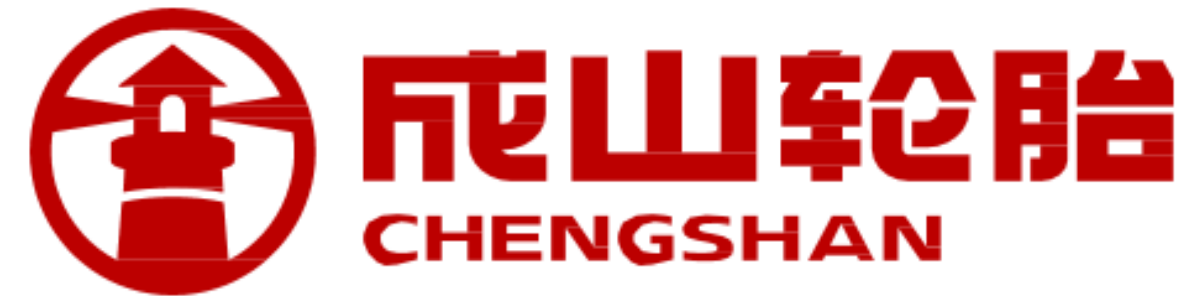

中国司机的选择

- 品牌价值381.95亿 • 2002年评为中国驰名商标

AUSTONE
澳通轮胎

与爱相伴，不负分秒

FORTUNE
富神轮胎

澎湃于心，勇者自强



PRINX 浦林

为电动时代而生

电动轮胎「双效提升」

能源效率+性能效率 轮胎升级新选择



XLAB COMFORT EV 创域·彗星版

PRINX 浦林

定位“为电动时代而生”，从品牌到市场与渠道，持续探索，突破创新，为年轻人打造电动交通时代的生活方式。



浦林是首个获得

美国MUSE DESIGN AWARDS、巴黎DNA和意大利A' DESIGN AWARD三项国际大奖的国内轮胎品牌。

浦林轮胎多方面的变革与突破，让中国设计影响世界。



中国司机的选择

树立坚韧、敢担当的品牌个性，始终秉承着艰苦奋斗的精神。致力成为“中国制造”的行业代表，成为中国司机的首选。

成山乘用车产品品牌“华”系列

华韧，耐磨双盾、湿地性能一流，全胎侧烙印耀黑天鹅绒胎壁，雕刻专属祥云图腾，开创轮胎新国潮典范。

华悦，“华”系列旗下首款城市SUV轮胎，稳驾双控技术，加强型双层胎体结构，多变路况从容应对。胎侧天鹅绒触感麒麟纹饰面，提升感官品质，彰显中国特色。

比耐久 选华韧
耐磨双盾 让轮胎跑更远
成山华系列旗下首款高性能乘用车轮胎



开SUV 选华悦
稳驾双控 让出行稳稳的

AUSTONE 澳通轮胎

围绕积极主动、以人为本、周全守护的品牌特性，致力于以优质的产品与服务，为所爱之人打造安全无忧的自在旅途。

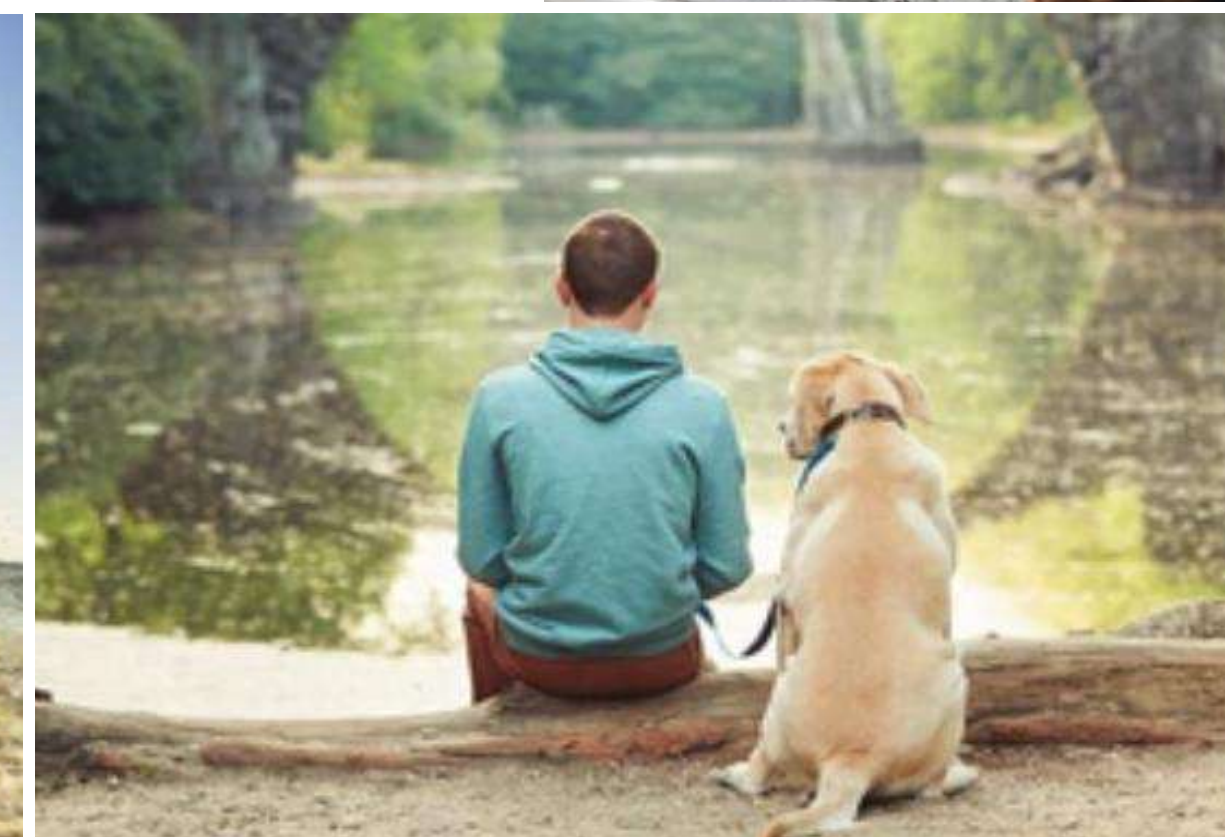



FORTUNE
TIRES

DRIVE FORWARD

Powering those strong minds to keep driving forward.

FAM211

FORTUNE
富神轮胎

围绕解决问题、自我掌控、不断进步的品牌特性，不断反躬自省、革新技术，致力于推进轮胎产品的性能，为每个以意志为驱的强者而创立。



FORTUNE
富神轮胎

澎湃于心 勇者自强

与坚毅者共勉，
永不停步，所向无前

FAM211

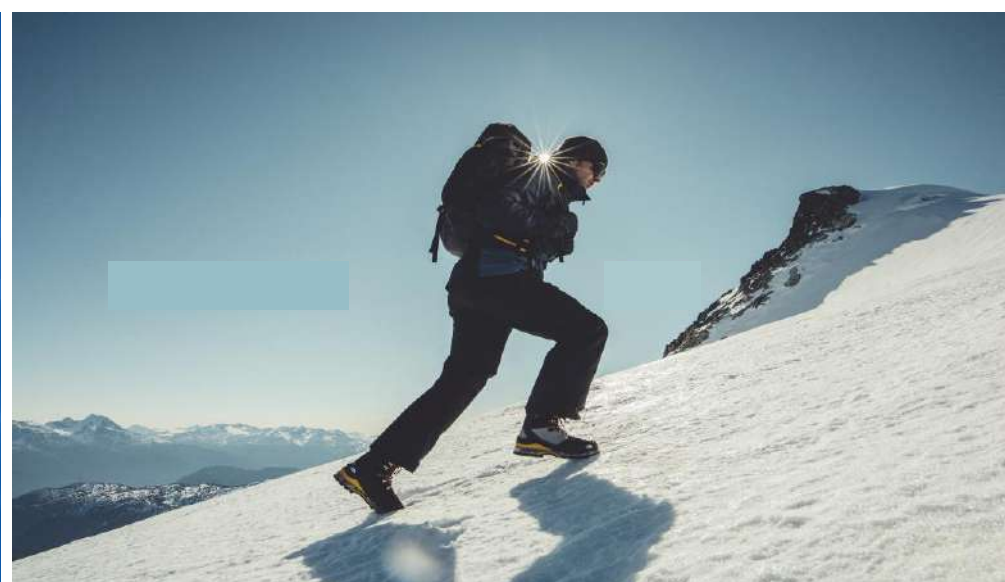

FORTUNE
TIRES

DRIVE FORWARD

Powering those strong minds to keep driving forward.

FAM211

品牌营销活动 | 影响力覆盖全球



浦林成山 发展战略



绿色化 | 绿色制造&绿色供应链

践行绿色发展理念

“绿色工厂、绿色产品、绿色供应链”为核心的绿色制造体系
获得“绿色先锋企业”和“绿色供应链管理企业”称号。

绿色节能减排

利用厂房屋顶进行光伏发电

累计光伏发电**7,656万KW/H**

相当于一年内每晚点亮**104,877盏**路灯

能源循环利用

山东生产基地新建污水处理设施

每年可节约水资源约**40万+**立方米

相当于装满**7,000+**个40HQ标准集装箱



工信部-绿色设计示范企业

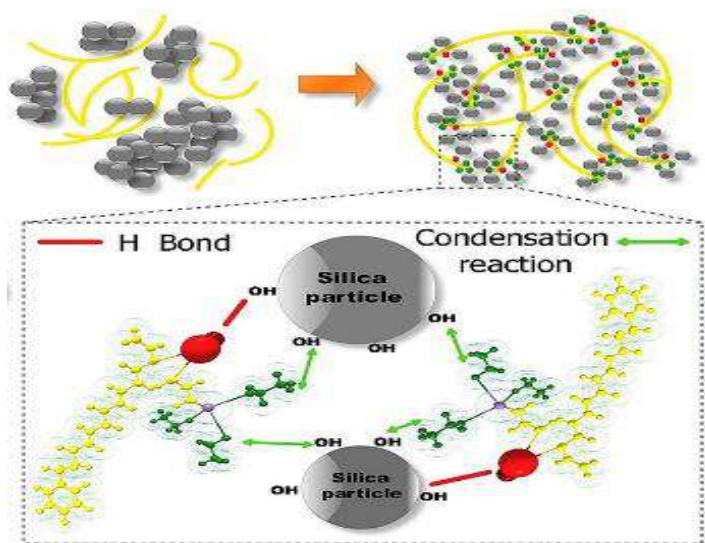

设计

供应

工信部-绿色供应链管理企业



绿色
智造

中橡协-国际首创移动翻新



回收

制造

工信部-绿色制造示范企业、石油和
化工行业能效领跑者标杆企业

能源循环利用-污水处理设施



使用

低滚阻新能源产品



绿色化 | 绿色产品



工信部 **首批绿色工厂**

1025个 绿色产品



采用**超高行驶**里程绿色轮胎产品关键技术

代表规格 **12R22.5 FH123**
行驶里程超过 **40万** 公里



新能源电动车超低滚阻
性能表现为行业标杆

全新浦林**EV创域、探域系列**上市, 滚阻达到**欧盟A级**标准。

高里程新能源公交车专用产品**C901**, 性价比超过国际一流品牌。



实现轮胎全生命周期管理



追求轮胎全生命周期
价值最大化

探索轮胎循环利用
新模式

国内率先引进法国PLM 绿色 全生命周期管理，实现轮胎全生命周期的追溯、管理与回收再利用，追求轮胎全生命周期价值最大化，探索轮胎循环利用新模式。



社会责任



环保在行动



公益活动

成山集团“慈善冠名基金”用于救助家庭经济困难学生和弱势群体



2008年，支援汶川地震受灾群众



2022年，泰国洪涝灾害生活急救物资捐赠活动



泰国工厂向当地医院、学校捐献口罩，开展跨国公益活动



成就 美好生活

TOGETHER, A BETTER LIFE.

